

Cambridge Brass
P.O. Box 249
140 Orion Place
Cambridge, Ontario
Canada N1R 5V1
Tel: (519) 621-5520
Fax: (519) 621-8674
http://www.cambridgebrass.com

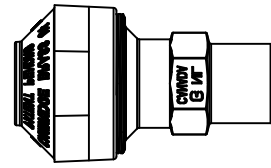

MODEL NO. 117NL

U x F

CAMBRIDGE COUPLING

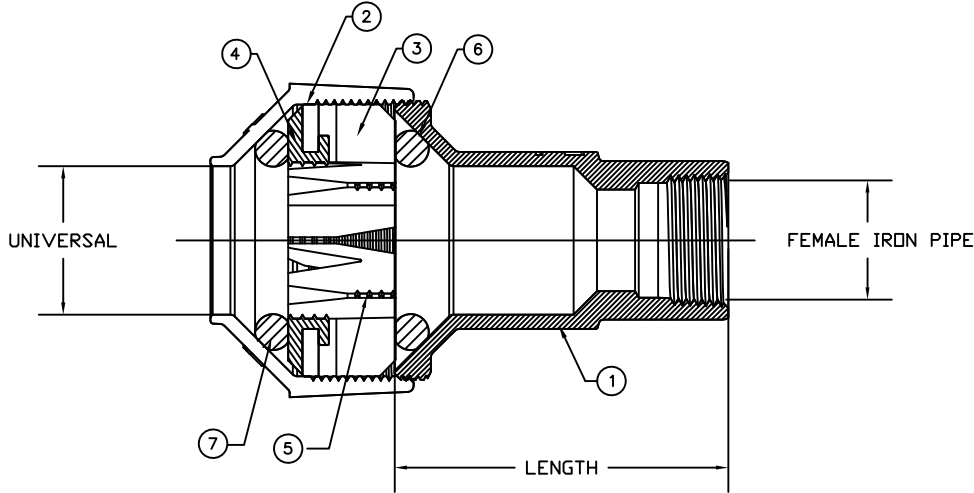

PARTS AND MATERIAL:

1. COUPLING BODY: CAST BRASS, NO LEAD ALLOY C89833
2. NUT: CAST BRASS, NO LEAD ALLOY C89833
3. GRIPPER BODY: MATERIAL PLASTIC, NORYL
4. TOOTH (FIRST ROW): 301 STAINLESS STEEL
5. TOOTH (SECOND ROW): 301 STAINLESS STEEL
6. PRESSURE SEAL: EPDM RUBBER
7. DIRT SEAL: EPDM RUBBER

FEATURES:

- ALL COMPONENTS CONFORM TO AWWA C800-05 (ASTM B-584 UNS NO C89833 FOR ALL BRASS PARTS)
- CSA CLASSIFIED TO ANSI/NSF STANDARD 61-8.
- BODY PROVIDES LARGE, RUGGED WRENCH FLATS FOR PROPER INSTALLATION.
- 300 PSI WORKING PRESSURE

Cambridge Brass considers the information in this submittal form to be correct at the time of publication. Item and option availability, including specifications, are subject to change without notice.

CATALOG NO.	U	F	RANGE[IN]	LENGTH[IN]	APROX.WEIGHT[LB]
117NL-U2F3	5/8"	3/4"	.600"-.900" x 3/4"	3.26	1.79
117NL-U3F3	3/4"	3/4"	.735"-1.135" x 3/4"	3.26	1.95
117NL-U4F4	1"	1"	1.000"-1.400" X 1"	3.36	2.70
117NL-U5F4	1 1/4"	1"	1.300"-1.700" x 1"	3.36	3.02
117NL-U5F6	1 1/4"	1 1/2"	1.300"-1.700" x 1 1/2"	3.36	3.33
117NL-U6F6	1 1/2"	1 1/2"	1.600"-2.000" x 1 1/2"	3.76	3.29
117NL-U7F6	2"	1 1/2"	1.969"-2.381" x 1 1/2"	3.76	3.68

Submitted by: